

Specification number: 24760029 – 10EV-C12-iTap-EN

Item number: 10LEV-C12-iTap-EVOH70-EN

### Product description:

The packaging is designed for storing wine, fruit juices and other liquid foods and beverages. They are made of multilayer films that provide high mechanical strength, do not transmit light, have high barrier properties and are resistant to high temperatures ( 5°C to 85°C ).

## PARAMETERS

Capacity	10 L	Material	PE30/METPET12/PE35 + LLDPE45
Size A (inside/out)	495 / 513 mm..	Tap model	iTap
Size B (inside/out)	375 / 393 mm.	Tap position	Left 12 h
Size C	70 mm.	Weight (1 pcs.)	0.059 kg.
Size D	187.50 mm.	Marking	YES
Size Y	5 mm.	Size F	
Size Z	35 mm.	Size E	Избор на елемент.
Tolerance	± 5 mm.		

## Product scheme

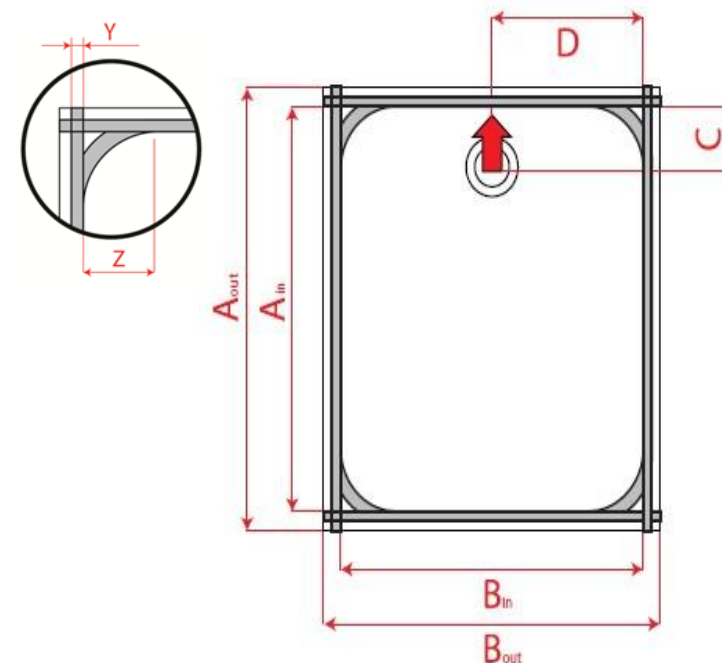

## Mechanical properties

Indicators	Min. Value
Seal strength, N-m	333,3
Seal tightness, Pa	392
Seal width, mm	5 mm. (± 2mm.)

## Type of tap and sleeve

Tap	iTAP	Sleeve	HS (HR) I
Material	PP / HDPE / PE	Material	LDPE
Color	Red / White	Color	Natural
Tap direction	12 h	Tapping depth	9.5

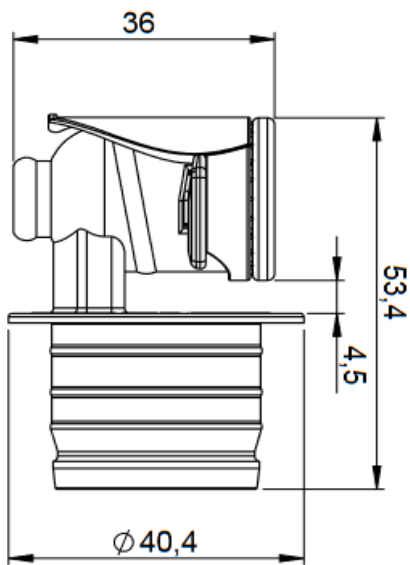
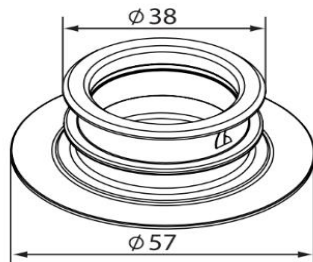

## Packaging

Type of package	Dimensions	Count	Weight
Box	800 x 600 x 210	250 pcs.	16.36 kg.
Pallet	800 x 1200 x 2350-10	5000 pcs.	347.14 kg.
Boxes per pallet	20 pcs.		

The bags are packed in boxes sealed with tape. The boxes are stacked on a pallet. Each pallet is well wrapped all the way round with high resistant stretch foil.

## Material type

Transperant standard barrier bags

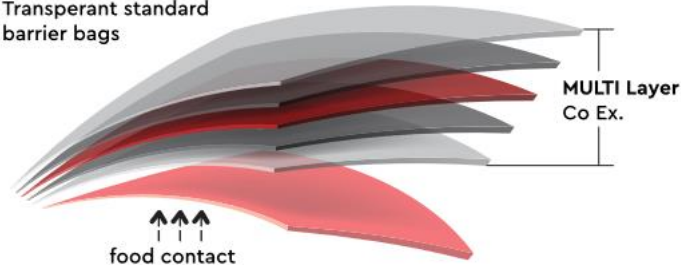

PE
EVOH 70 $\mu$
LLDPE 45 $\mu$

## Outer layer

Material	PE/EVOH70/PE
Color	Transparent
Thickness	70 microns

## Inner layer

Material	LLDPE45
Color	Transparent
Thickness	45 microns

## Barrier properties:

Specification oxygen permeability - < 1.0 cm<sup>3</sup>/m<sup>2</sup>/day @ 23°C and 50%  
Vapour permeability - < 1 g/m<sup>2</sup>/day (at 38°C and 90% relative humidity).

## Recommendations and Conditions for use and storage of the product:

**Conditions for filling** – The bags must be acclimatised before use. Minimum 2 hours at air temperature - from 18 °C to 25 °C .

Liquid temperature when filling - 5 °C to 85 °C .

Empty bags should be stored in odourless, ventilated rooms, in the absence of direct sunlight, at a distance of at least 1 metre from heating appliances, at a temperature of minus 5 °C to 40 °C and a relative humidity of no more than 80%.

**Warranty storage period** – 12 months from the date of manufacture, if storage conditions are met.

Client: .....

Manufacturer: **PROBOX Ltd.**

Person in charge: .....

Person in charge: Nikolay Trifonov

Signature .....

Signature .....

Date .....

Date 17.2.2024 g.