

Specification number: 24760070 – 10LM-C12-iTAP

Item number: 10LM-C12-iTAP-P30M12P35P45

## Product description:

The packaging is designed for storing wine, fruit juices and other liquid foods and beverages. They are made of multilayer films that provide high mechanical strength, do not transmit light, have high barrier properties and are resistant to high temperatures ( 5°C to 85°C ).

## PARAMETERS

Capacity	10 L	Material	PE30/METPET12/PE35 + LLDPE45
Size A (inside/out)	495 / 513 mm.	Tap model	iTap
Size B (inside/out)	375 / 393 mm.	Tap position	Left 2h
Size C	70 mm.	Weight (1 pcs.)	0.0657 kg
Size D	187,5 mm.	Marking	YES
Size Y	5 mm.	Size F	
Size Z	35 mm.	Size E	
Tolerance	± 5 mm.		

## Product scheme

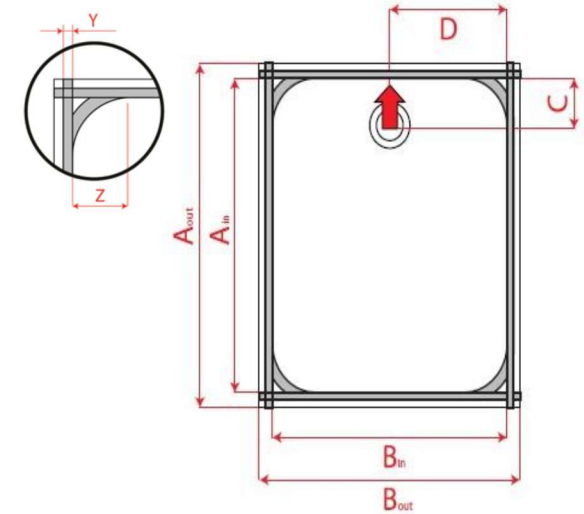

## Mechanical properties

Indicators	Min. Value
Seal strength, N-m	333,3
Seal tightness, Pa	392
Seal width, mm	5 mm. (± 2mm.)

Type of tap and sleeve

Tap	ITAP - SOLO	Sleeve	HS (HR) I
Material	PP / HDPE / PE	Material	LDPE
Color	Red / White	Color	Natural
Tap direction	12 h	Tapping depth	9.5

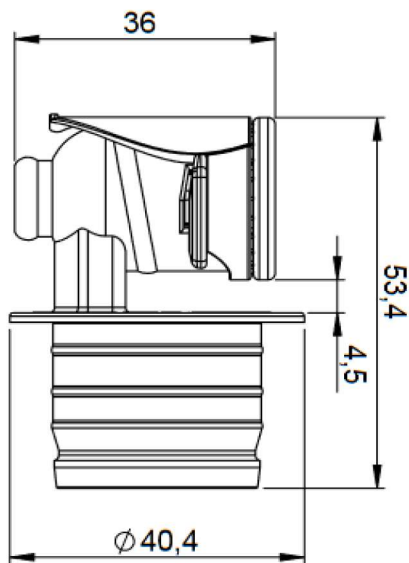
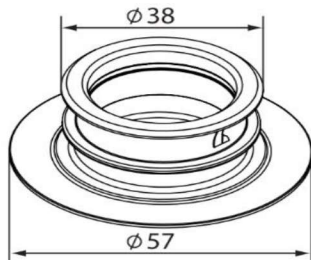

Packaging

Type of package	Dimensions	Count	Weight
Box	800 x 600 x 210	250	18,02 kg.
Palet	800 x 1200 x 2350 - 10	5000	380,40 kg.
Cutii/palet	20 buc.		

The bags are packed in boxes sealed with tape. The boxes are stacked on a pallet. Each pallet is well wrapped all the way round with high resistant stretch foil.

Material type

Metallic standard barrier bag

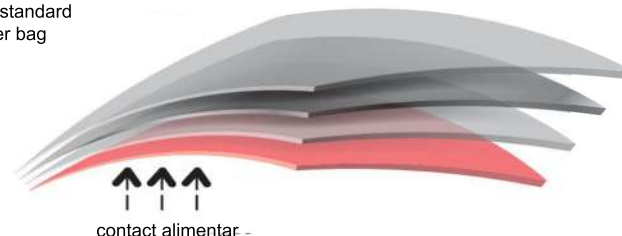

PE 30μ

MET PET 12μ

PE 35μ

LLDPE 45μ

Outer layer

Material	PE30 / METPET12 / PE35
Color	Metalizat (argintiu)
Thickness	83 microni

Inner layer

Material	LLDPE45
Color	Transparent
Thickness	45 microni

Barrier properties:

Specification oxygen permeability - < 1.0 cm<sup>3</sup>/m<sup>2</sup>/day @ 23°C and 50%  
Vapour permeability - < 1 g/m<sup>2</sup>/day (at 38°C and 90% relative humidity).

Recommendations and Conditions for use and storage of the product:

Conditions for filling – The bags must be acclimatised before use. Minimum 2 hours at air temperature - from 18 ° C to 25 ° C .

Liquid temperature when filling - 5 ° C to 85 ° C .

Empty bags should be stored in odourless, ventilated rooms, in the absence of direct sunlight, at a distance of at least 1 metre from heating appliances, at a temperature of minus 5 °C to 40 °C and a relative humidity of no more than 80%.

Warranty storage period – 12 months from the date of manufacture, if storage conditions are met.

Client: .....

Manufacturer: : PROBOX Ltd.

Person in charge: .....

Person in charge: Nikolay Trifonov

Signature .....

Signature .....

Date .....

Date: 20.5.2024 g.